

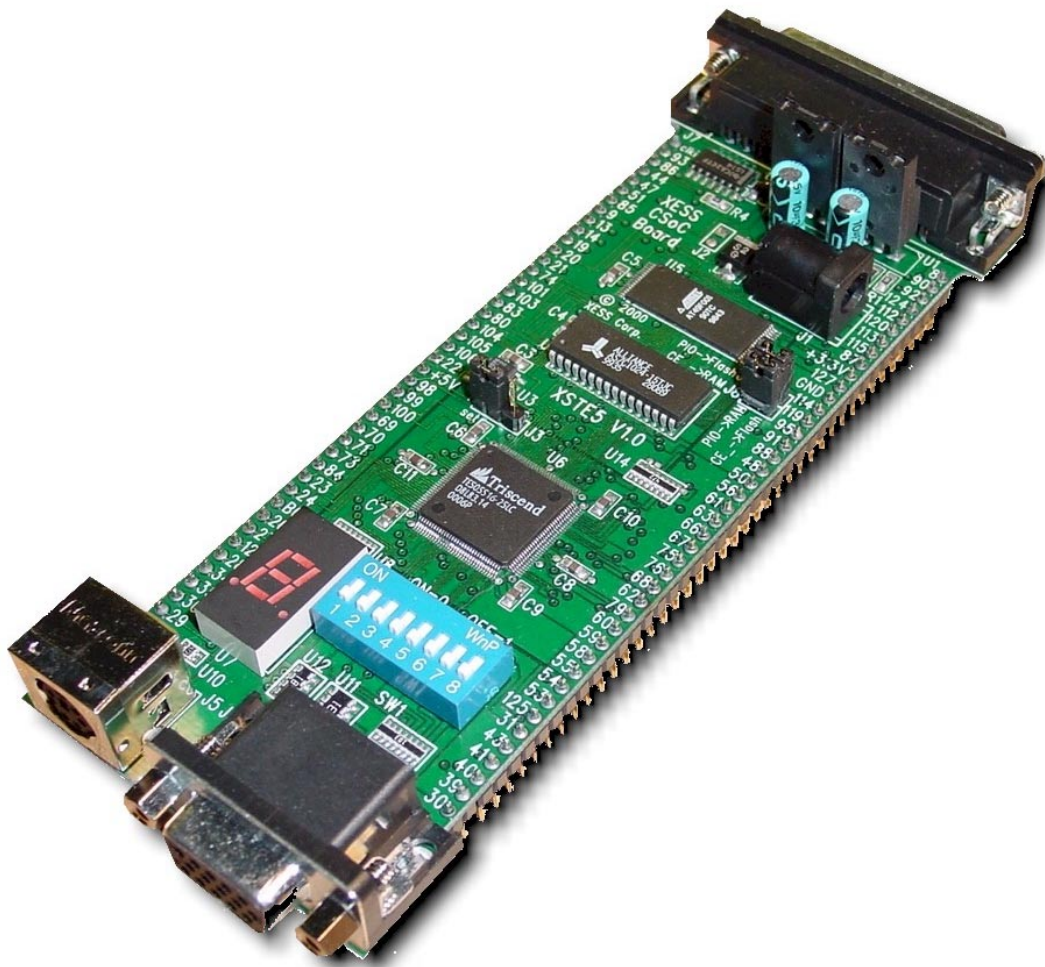

# CSoc Board Manual



© 2000 by X Engineering Software Systems Corp., Apex, North Carolina 27502

All rights reserved. No part of this text may be reproduced, in any form or by any means, without permission in writing from the publisher.

The author and publisher of this text have used their best efforts in preparing this text. These efforts include the development, research, and testing of the theories and programs to determine their effectiveness. The author and publisher make no warranty of any kind, expressed or implied, with regard to these programs or the documentation contained in this text. The author and publisher shall not be liable in any event for incidental or consequential damages in connection with, or arising out of, the furnishing, performance, or use of these programs.

XESS and CSoC Board are trademarks of X Engineering Software Systems Corp. Triscend and FastChip are trademarks of Triscend Corporation. Other product and company names mentioned are trademarks or trade names of their respective companies.

The software described in this text is furnished under a license agreement. The software may be used or copied under terms of the license agreement.

# XSTE5 CSoC Board Manual

---

## Take Notice!!

- The XSTE5 CSoC Board requires an external power supply to operate! It does not draw power through the downloading cable from the PC parallel port.
- If you are connecting a 9VDC power supply to your CSoC Board, please make sure the center terminal of the plug is positive and the outer sleeve is negative.
- The CSoC Board uses a programmable oscillator with a default frequency of 50 MHz. You must reprogram the oscillator if you want to use another frequency. The procedure for doing this is described on page 6.

## XSTE5 CSoC Board Components

The XSTE5 CSoC Board is shown in Figure 1. It contains the following components:

**Triscend TE505 CSoC:** The TE505 contains an enhanced 8032 microcontroller, two DMA controllers, 16 KBytes of internal SRAM, and an array of 512 programmable logic cells.

**128 KByte SRAM:** The 15ns SRAM can be used for general-purpose data storage or it can hold instructions and data for the microcontroller in the CSoC.

**128 KByte Flash RAM:** The Flash RAM can store the configuration and programs for the CSoC and restore them after a power interruption.

**100 MHz Programmable Oscillator:** A nonvolatile programmable divider in this oscillator chip lets it output a clock in the frequency range of 50 KHz to 100 MHz to the rest of the CSoC Board.

**Seven-Segment LED:** The CSoC can show simple status indicators through this display device:

**DIP Switch:** The CSoC can receive up to eight logic inputs from this bank of switches.

**Parallel Port:** CSoC configurations are downloaded and debugged on the CSoC Board using a PC connected to the parallel port connector.

**PS/2 Port:** The CSoC can receive data from a standard keyboard or mouse through this connector.

**VGA Port:** The CSoC can generate video signals for a VGA monitor attached to this connector.

**Prototyping Interface:** The majority of the I/O pins of the CSoC are made available to external devices through this set of 84 pins on the underside of the CSoC Board.

**Power Jack:** A 9V DC input to this jack is converted into the +3.3V and +5V supplies required by the rest of the CSoC Board circuitry.

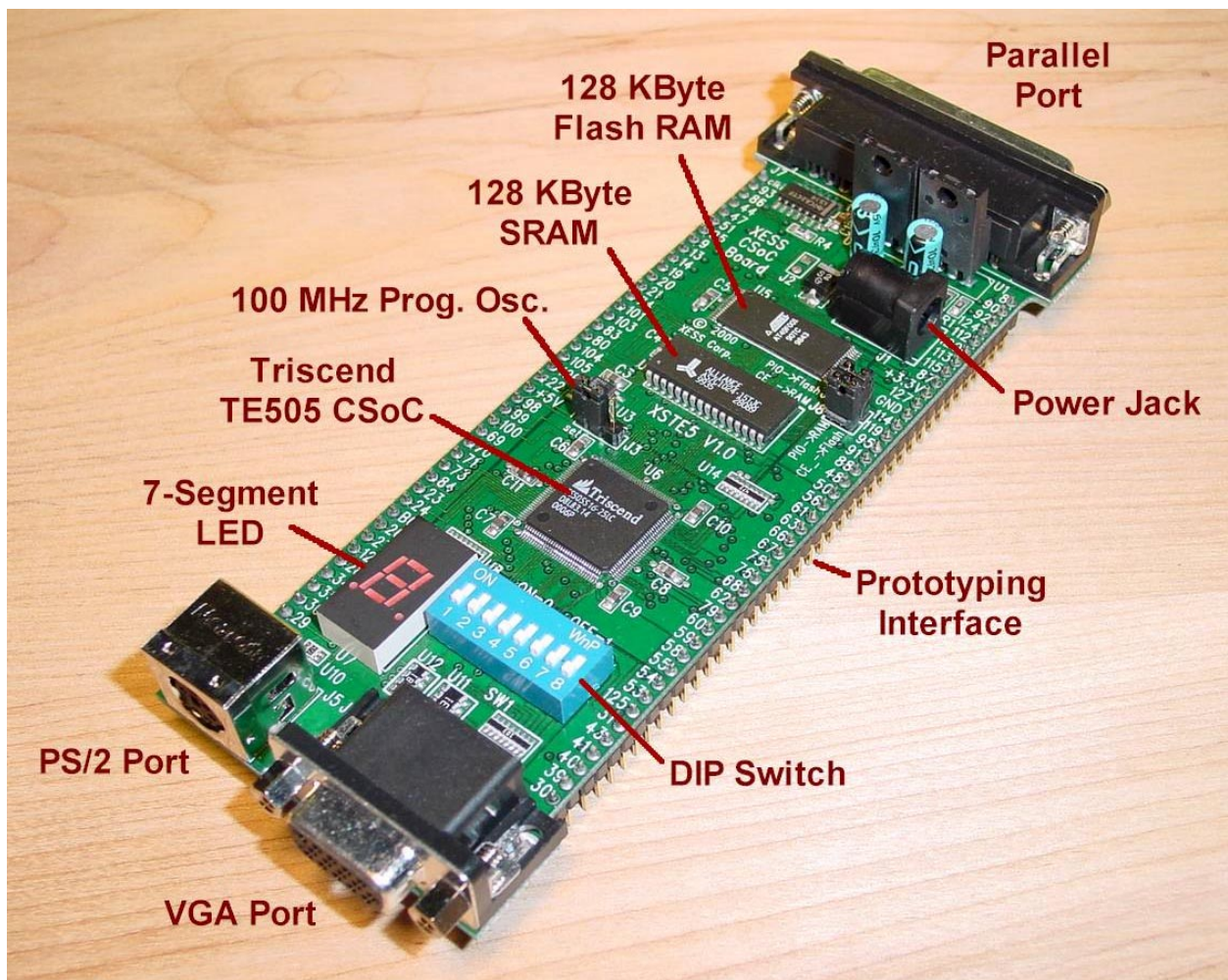

Figure 1: XSTE5 CSoC Board.

## Applying Power to Your CSoC Board

You can use your CSoC Board in two ways, distinguished by the method you use to apply power to the board.

### *Using a 9VDC wall-mount*

You can use your CSoC Board all by itself to experiment with logic and microcontroller designs. Just place the CSoC Board on a non-conducting surface as shown in Figure 2. Then apply power to jack J1 of the board from a 9V DC, 500 mA wall-mount transformer with a 2.1 mm female, center-positive plug. The on-board regulators will convert the 9V into the +3.3V and +5V supplies required by the rest of the CSoC Board circuitry.

### *Solderless Breadboard Installation*

The two rows of pins from your CSoC Board can be plugged into a solderless breadboard with holes spaced at 0.1" intervals. (One of the A.C.E. protoboards from 3M is a good choice.) Once plugged in, all the pins of the Triscend CSoC, SRAM, and Flash RAM are accessible to other circuits on the breadboard. (The numbers printed next to the rows of pins on your CSoC Board correspond to the pin numbers of the Triscend CSoC.) Power can still be supplied to your CSoC Board though jack J1, or power can be applied directly through several pins on the underside of the board. Just connect +5V, +3.3V, and ground from an external power supply to the pins with those labels.

## Connecting a PC to Your CSoC Board

The 6' downloading cable included with your CSoC Board connects it to a PC. One end of the cable attaches to the parallel port on the PC and the other connects to the female DB-25 connector (J7) at the top of your CSoC Board as shown in Figure 2.

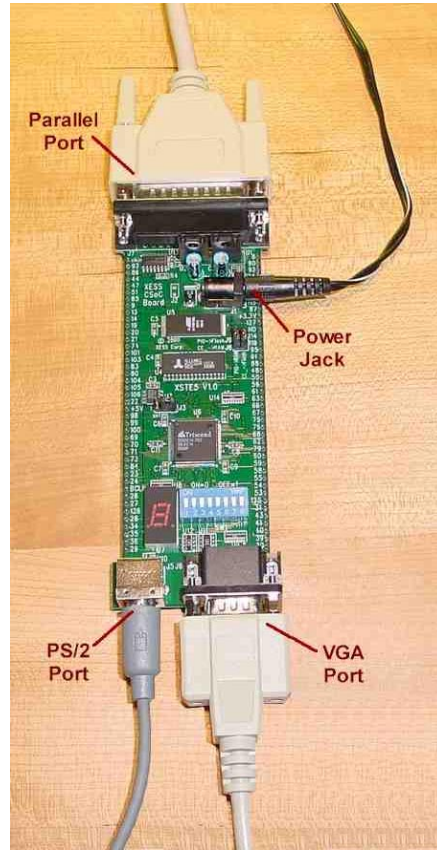

**Figure 2: Connections from the XSTE5 CSoC Board to external devices.**

### **Connecting a VGA Monitor to Your CSoC Board**

You can display images on a VGA monitor by connecting it to the VGA port (connector J6) at the bottom of your CSoC Board (see Figure 2). You will have to download a VGA driver circuit to your CSoC Board to actually display an image.

### **Connecting a Mouse or Keyboard to Your CSoC Board**

You can accept inputs from a keyboard or mouse by connecting it to the PS/2 port (connector J5) at the bottom of your CSoC Board (see Figure 2).

## Setting the Jumpers on Your CSoC Board

The CSoC Board contains two sets of jumpers: one jumper that controls the mode of the programmable oscillator, and a dual-jumper that selects which memory device holds the program instructions and data for the CSoC.

The programmable oscillator is controlled by jumper J3. The position of the shunt on J3 determines the oscillator mode when power is applied to the CSoC Board. You should disconnect the power supply from jack J1 and the downloading cable from parallel port J7 before moving the shunt on J3. Otherwise the programmable oscillator will ignore the shunt setting. The oscillator will respond to the shunt setting when power is restored to the CSoC Board. The two shunt settings for J3 are discussed below.

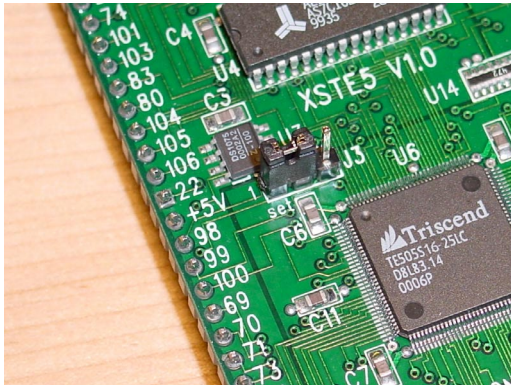

The shunt on jumper J3 should be in the "set" position if you want to program the frequency of the oscillator on the CSoC Board. Then you can use a software utility to set the programmable frequency divider in the oscillator. The divisor value is stored in Flash within the oscillator chip so it will not be cleared if power is removed from the CSoC Board.

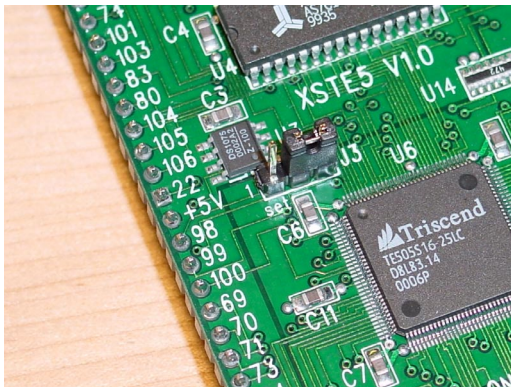

The shunt on jumper J3 should be in the "osc" position when you want the oscillator to output a clock signal to the CSoC. The programmable oscillator will divide its internal 100 MHz frequency source by the divisor value stored in Flash. This is the default position for the shunt.

The connection of the SRAM and Flash RAM memory chips to the CSoC is controlled by jumpers J8 and J9. The orientation of the shunts on J8 and J9 will attach the chip-enable of one of the memory devices to the dedicated chip-enable output of the CSoC. Then the CSoC will fetch instructions and data from this memory device. The chip-enable of the other memory device will be connected to a general-purpose I/O pin of the CSoC. The CSoC can still access this memory chip but it requires some extra programming effort on your part to do so. The two possible shunt settings for J8 and J9 are shown below.

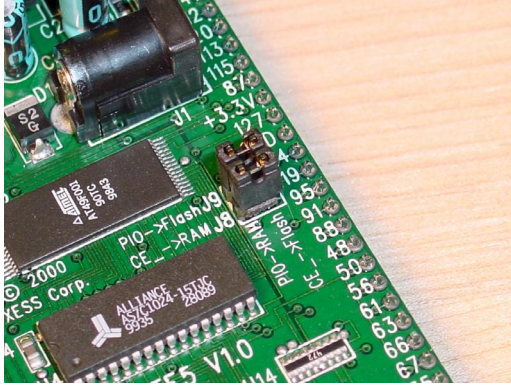

The CSoC will get instructions and data from the 128 KByte SRAM when the shunts are oriented horizontally on jumpers J8 and J9. This is the default shunt setting and should be used when you are developing a CSoC design because downloading into the SRAM is much faster than programming the Flash RAM.

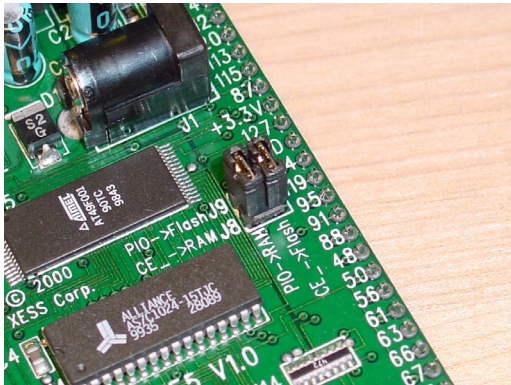

The CSoC will get instructions and data from the 128 KByte Flash RAM when the shunts are oriented vertically on jumpers J8 and J9. This is the setting to use when your CSoC design is finalized and you want to store it in the Flash RAM. Then the CSoC will initialize itself from the Flash whenever power is applied to the CSoC Board.

## Programming the Oscillator Frequency

Before programming your CSoC Board, you need to set the programmable oscillator to a frequency that is compatible with the Triscend TE505 CSoC. The CSoC on your board has a maximum operating frequency of 25 MHz so the oscillator output clock can't be any higher than that.



Click on the  icon to begin the oscillator programming process. The window shown below will appear.

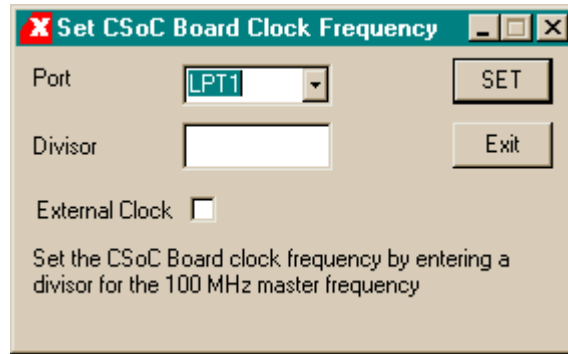

Select the PC parallel port that is connected to your CSoC Board from the drop-down menu as shown below. In the majority of cases, this will be LPT1.

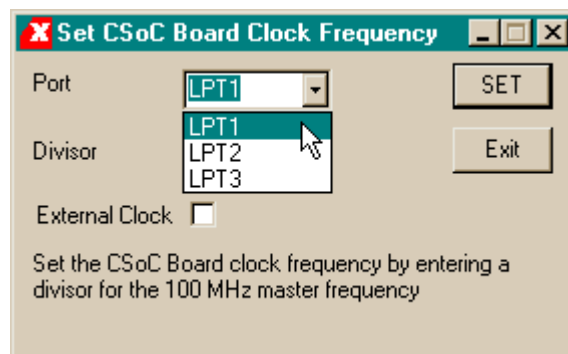

Next, type in the divisor for the 100 MHz master frequency. Allowable divisors are in the range [1,2052]. If you want to run the CSoC at its maximum speed of 25 MHz, enter 4 into the Divisor box.

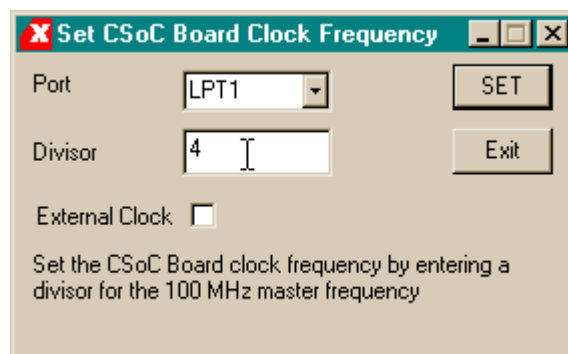

Then click on SET to begin sending the programming commands to the oscillator chip.

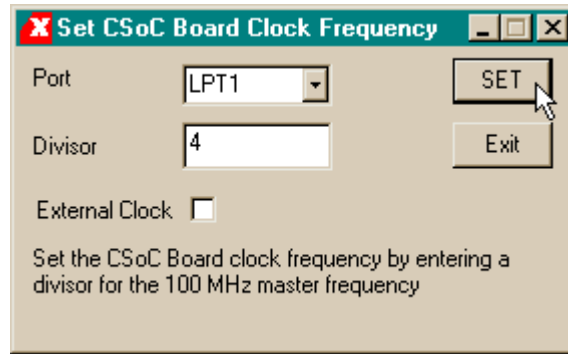

The program will provide you with a list of steps to perform that will place the oscillator chip in the programming mode. Once you have done these steps in the given sequence, click on OK.

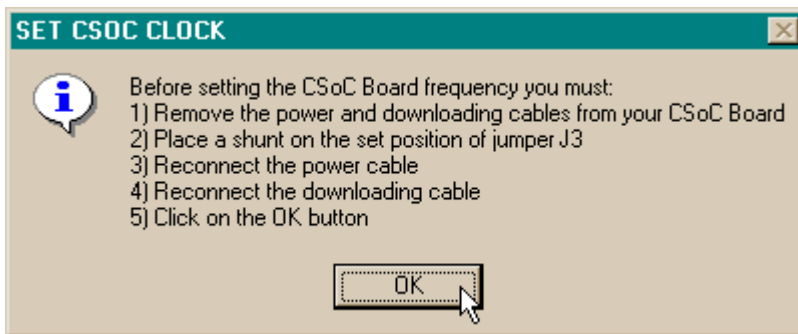

The program will load the divisor into the oscillator chip very quickly. Then it will give you a list of steps to do that will end the oscillator programming mode and cause it to output the frequency you specified. Once you have done these steps in the given sequence, click on OK.

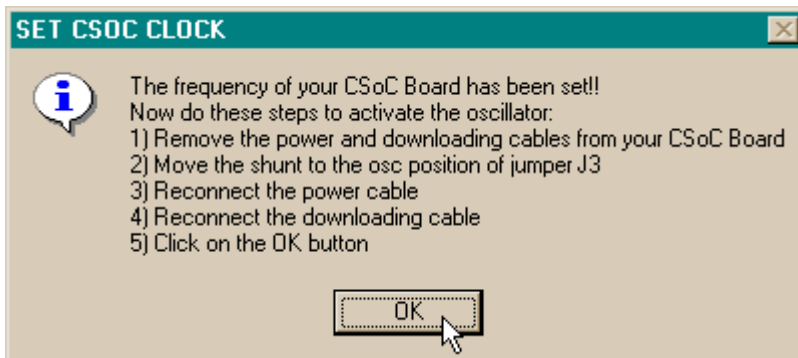

At this point, the programmable oscillator should be generating a clock for the CSoC derived from its internal 100 MHz frequency source.

If you wish to use an external clock to drive the CSoC Board instead of the 100 MHz oscillator, just click on the External Clock checkbox and repeat the steps listed above. Then attach your external clock to the clkin pin in the upper left-hand corner of your CSoC Board. The external clock will be divided by the divisor in the programmable

oscillator and then passed to the CSoC. The maximum allowable external clock frequency is 50 MHz.

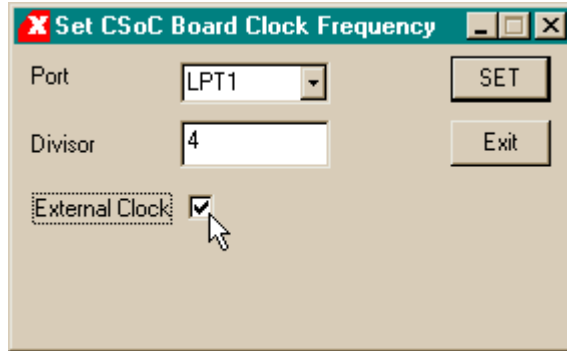

## Testing Your CSoC Board



You can check the health of your CSoC Board by clicking on the **CSoC Test** icon. Press on the TEST button in the **Test CSoC Board** window.

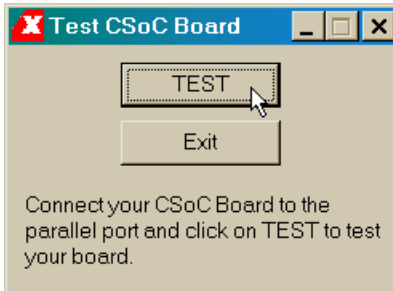

The LED segments on your CSoC Board will light in sequence and the **Test CSoC Board** window will indicate that the board test is in progress.

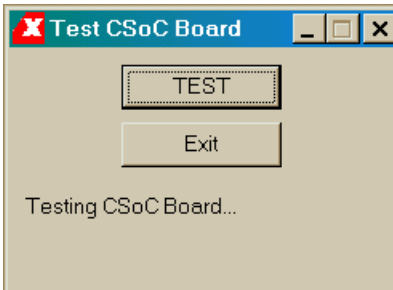

If your CSoC Board passes the test, you will see a O displayed on the seven-segment LED and the following window will appear. You can now proceed with designing CSoC-based systems using your CSoC Board.

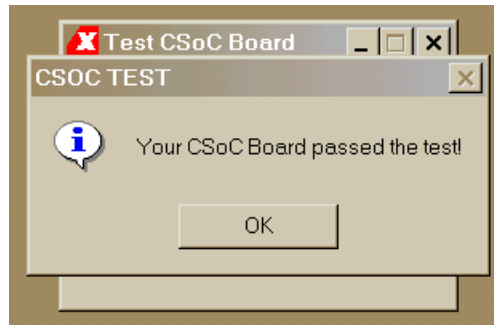

If your CSoC Board fails the test, you will see a window that gives you several items to check that may have caused the failure.

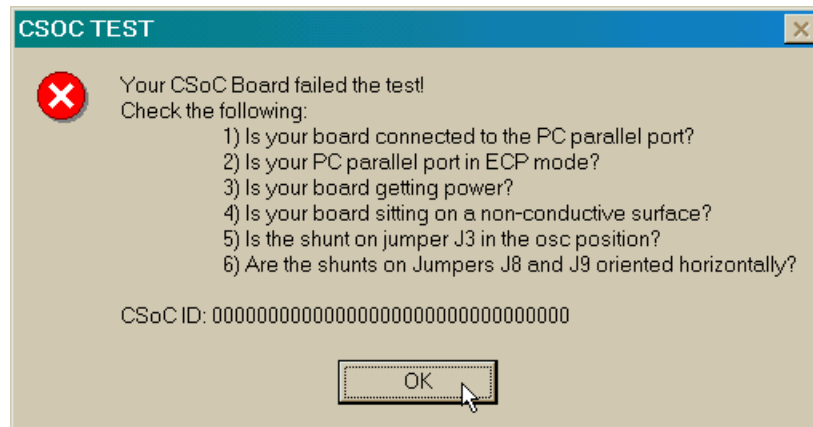

If all these checks are positive, then test the board using another PC. In our experience, 99.9% of all problems are due to the parallel port. If you cannot get your CSoC Board to pass the test, then contact XESS Corp. at [help@xess.com](mailto:help@xess.com).

## CSoC Board Circuitry

A high-level view of the CSoC Board circuitry is shown in Figure 3.

The eight data pins from the PC parallel port terminate on the CSoC. D0 controls the CSoC reset pin and is normally not connected (jumper J2 is left open). D1 and D2 attach to the TMS and TCK pins that control the JTAG state machine in the CSoC. Configuration and debugging commands are sent to the TDI input of the CSoC JTAG port over D3. The upper nybble of the parallel port data bits (D4–D7) is available as general-purpose inputs to the CSoC from the PC as are the four control outputs from the parallel port (C0–C3). Control bit C2 passes through two Schmitt-trigger inverters before reaching one of the global buffer inputs (GBUF5) of the CSoC, so this bit can be

used to pass a low-speed clock from the PC. The other data and control bits have slow edge transition times and are not suitable for use as clocks unless you use the Schmitt-trigger option on the CSoC input pins.

The CSoC can communicate back to the PC through the parallel port status inputs S3–S7. The most-significant status bit (S7) is used by the TDO pin of the CSoC JTAG port to pass debugging information back to the PC. The remaining status bits are available as general-purpose outputs from the CSoC back to the PC.

A DIP switch with eight individual SPST switches is attached to the CSoC. A switch is open when it is in the OFF position and the corresponding pin of the CSoC is pulled to the supply voltage through a pull-up resistor. When the switch is ON (closed), it pulls the CSoC pin directly to ground.

The CSoC receives data from a keyboard or mouse through the two inputs connected to the PS/2 port. The data input delivers a serial data stream which is accepted into the CSoC on the falling edges of the clock input.

Seven outputs from the CSoC drive a seven-segment LED digit. These same outputs also drive the inputs to a VGA monitor. Horizontal and vertical sync outputs from the CSoC generate a stable timing reference for the frames of video sent to the monitor. The other six outputs determine the color of the current pixel in the video frame. Sixty-four pixel colors are possible (4 levels of red × 4 levels of green × 4 levels of blue).

The programmable oscillator output goes directly to the input of the CSoC.

The CSoC can write and read data to and from a 128 KByte SRAM and a 128 KByte Flash RAM on the CSoC Board. The SRAM and Flash RAM interface to the CSoC through a 17-bit address bus and an 8-bit data bus. Active-low chip-enable, output-enable, and write-enable control lines to the SRAM and Flash RAM are driven by the CSoC to activate the devices and either read or write a byte of data. The connection of the SRAM and Flash RAM memory chips to the CSoC is controlled by jumpers J8 and J9. The orientation of the shunts on J8 and J9 will attach the chip-enable of one of the memory devices to the dedicated chip-enable output of the CSoC. Then the CSoC will fetch instructions and data from this memory device. The chip-enable of the other memory device will be connected to a general-purpose I/O pin of the CSoC. The CSoC can still access this memory chip but it requires some extra programming effort on your part to do so.

The remaining pins of the CSoC are not committed to any specific function. They can be used as general-purpose I/O. Four of these pins also serve as inputs to global buffers in the CSoC so they are suitable as clock inputs to circuitry housed in the CSL of the CSoC. Two of the uncommitted pins (VSYS and SLAVE) control the startup and operating mode of the CSoC and you shouldn't use them unless you know what you are doing.

All the pins in Figure 3 that are tagged with a small rectangle are accessible to external systems through the pins which exit the bottom of the CSoC Board. The pins on the CSoC Board are labeled with the pin number of the CSoC pin to which they attach.

Condensed and expanded lists of the CSoC Board pins and their connections are given in Table 1 and Table 2, respectively. The detailed CSoC Board schematics follow these tables.

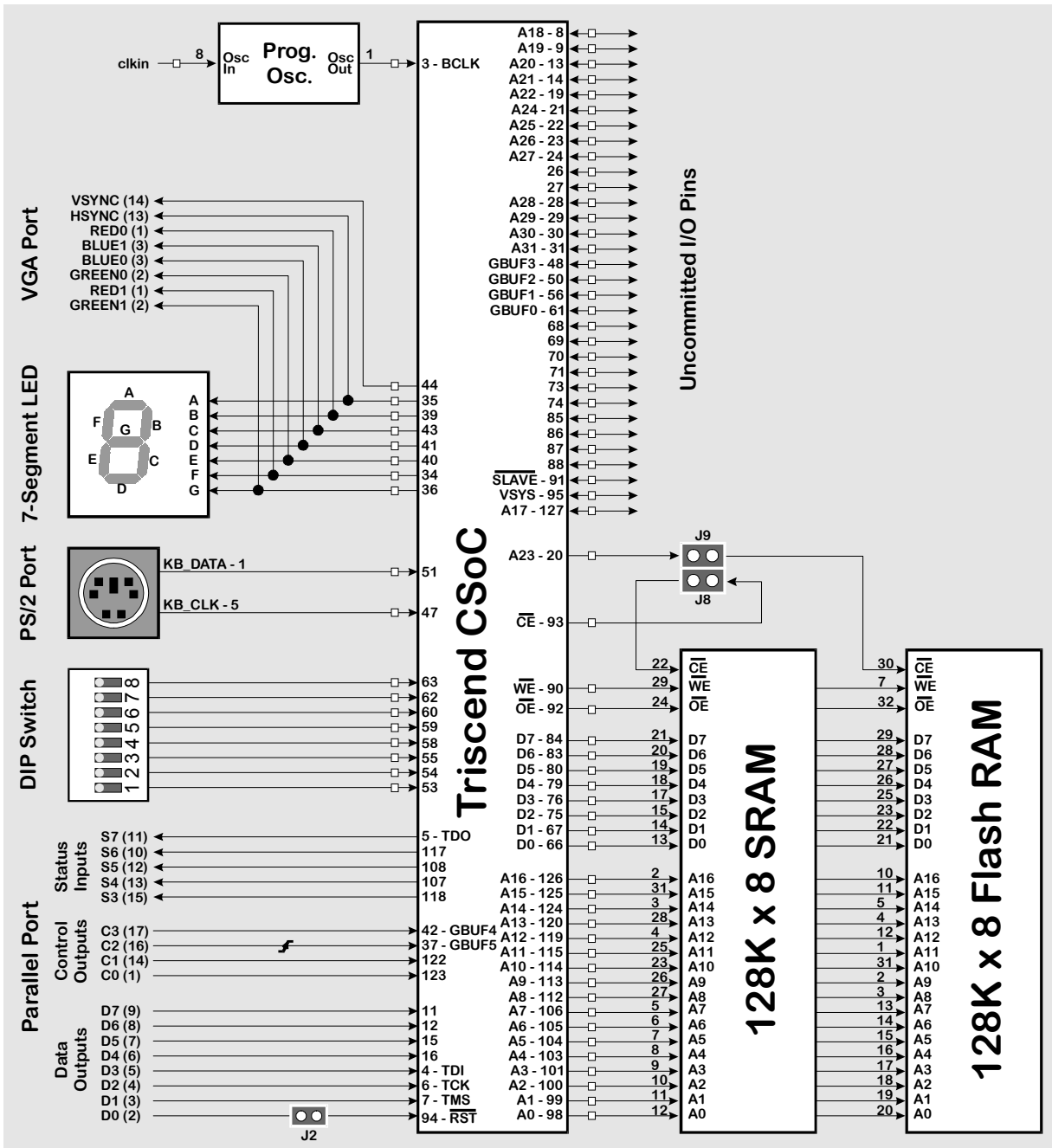

Figure 3: CSoC Board high-level schematic.

# XSTE5 CSoC Board Manual

**Table 1: Connections between the TE505 and other CSoC Board components.**

TE505		CSoC Board	
Pin	Name	Function	Pin
1	GND		
2	XTALIN		
3	XTALOUT		64, 13
4	TDI	PPORT D3 (5)	
5	TDO	PPORT S7 (11)**	
6	TCK	PPORT D2 (4)**	
7	TMS	PPORT D1 (3)	
8	A18		63
9	A19		71
10	GND		
11	PIO_0	PPORT D7 (9)	
12	PIO_1	PPORT D6 (8)	
13	A20		72
14	A21		73
15	PIO_2	PPORT D5 (7)	
16	PIO_3	PPORT D4 (6)	
17	VCC		2*
18	GND		
19	A22		74
20	A23	RAM/Flash /CE	75
21	A24		76
22	A25		1
23	A26		11
24	A27		12
25	GND		
26	PIO_8		14
27	PIO_9		15
28	A28		17
29	A29		21
30	A30		22
31	A31		27
32	VCC		

TE505		CSoC Board	
Pin	Name	Function	Pin
33	GND		
34	PIO_18	Red1, SegF	18
35	PIO_19	HSync, SegA	19
36	PIO_20	Green1, SegG	20
37	GBUF5	PPORT C2 (16)**	
38	GND		
39	PIO_21	Red0, SegB	23
40	PIO_22	Green0, SegE	24
41	PIO_23	Blue0, SegD	25
42	GBUF4	PPORT C3 (17)	
43	PIO_24	Blue1, SegC	26
44	PIO_25	Vsync	67
45	CVCC**		
46	CGND**		
47	PIO_26	PS/2 Clk	68
48	GBUF3		46
49	GND		
50	GBUF2		45
51	PIO_27	PS/2 Data	69
52	VCC		
53	PIO_28	Switch1	29
54	PIO_29	Switch2	30
55	PIO_30	Switch3	31
56	GBUF1		44
57	GND		
58	PIO_31	Switch4	32
59	PIO_32	Switch5	33
60	PIO_35	Switch6	34
61	GBUF0		43
62	PIO_38	Switch7	36
63	PIO_39	Switch8	42
64	VCC		

TE505		CSoC Board	
Pin	Name	Function	Pin
65	GND		
66	D0	RAM/Flash D0	41
67	D1	RAM/Flash D1	40
68	PIO_52		37
69	PIO_53		6
70	PIO_54		7
71	PIO_55		8
72	GND		
73	PIO_60		9
74	PIO_61		77
75	D2	RAM/Flash D2	39
76	D3	RAM/Flash D3	38
77	CVCC		
78	CGND		
79	D4	RAM/Flash D4	35
80	D5	RAM/Flash D5	81
81	VCC		
82	GND		
83	D6	RAM/Flash D6	80
84	D7	RAM/Flash D7	10
85	PIO_62		70
86	PIO_63		66
87	PIO_64		55
88	XDONE		47
89	GND		52
90	WE	RAM/Flash /WE	62
91	SLAVE		48
92	OE	RAM/Flash /OE	61
93	CE	RAM/Flash /CE	65
94	RST	PPORT D0 (2)	
95	VSYS		49
96	VCC		54

TE505		CSoC Board	
Pin	Name	Function	Pin
97	GND		
98	A0	RAM/Flash A0	
99	A1	RAM/Flash A1	
100	A2	RAM/Flash A2	
101	A3	RAM/Flash A3	
102	GND		
103	A4	RAM/Flash A4	
104	A5	RAM/Flash A5	
105	A6	RAM/Flash A6	
106	A7	RAM/Flash A7	
107	PIO_65	PPORT S4 (13)	
108	PIO_66	PPORT S5 (12)	
109	GND		
110	CVCC**		
111	CGND**		
112	A8	RAM/Flash A8	
113	A9	RAM/Flash A9	
114	A10	RAM/Flash A10	
115	A11	RAM/Flash A11	
116	VCC		
117	PIO_67	PPORT S6 (10)	
118	PIO_68	PPORT S3 (15)	
119	A12	RAM/Flash A12	
120	A13	RAM/Flash A13	
121	GND		
122	PIO_69	PPORT C1 (14)	
123	PIO_70	PPORT C0 (1)	
124	A14	RAM/Flash A14	
125	A15	RAM/Flash A15	
126	A16	RAM/Flash A16	
127	A17	Flash A17	
128	VCC		

**Table 2: Connections between the TE505 and other CSoC Board components.  
(Expanded version.)**

TE505		Pins	Parallel Port	VGA	PS/2	Switches	LEDs	Flash RAM	SRAM	Prog. Osc.
1	GND									
2	XTALIN									
3	XTALOU	13								Osc Out
4	TDI		D3 (5)							
5	TDO		S7 (11)**							
6	TCK		D2 (4)**							
7	TMS		D1 (3)							
8	A18	63								
9	A19	71								
10	GND									
11	PIO_0		D7 (9)							
12	PIO_1		D6 (8)							
13	A20	72								
14	A21	73								
15	PIO_2		D5 (7)							
16	PIO_3		D4 (6)							
17	VCC	2*								
18	GND									
19	A22	74								
20	A23	75						/CE-PIO	/CE-PIO	
21	A24	76								
22	A25	1								
23	A26	11								
24	A27	12								
25	GND									
26	PIO_8	14								
27	PIO_9	15								
28	A28	17								
29	A29	21								
30	A30	22								
31	A31	27								
32	VCC									
33	GND									
34	PIO_18	18		Red1			SegF			
35	PIO_19	19		Hsync			SegA			
36	PIO_20	20		Green1			SegG			
37	GBUF5		C2 (16)**							
38	GND									
39	PIO_21	23		Red0			SegB			
40	PIO_22	24		Green0			SegE			
41	PIO_23	25		Blue0			SegD			
42	GBUF4		C3 (17)							
43	PIO_24	26		Blue1			SegC			
44	PIO_25	67		Vsync						
45	CVCC**									
46	CGND**									
47	PIO_26	68			Clk					

# XSTE5 CSoC Board Manual

TE505		Pins	Parallel Port	VGA	PS/2	Switches	LEDs	Flash RAM	SRAM	Prog. Osc.
48	GBUF3	46								
49	GND									
50	GBUF2	45								
51	PIO_27	69			Data					
52	VCC									
53	PIO_28	29				Switch1				
54	PIO_29	30				Switch2				
55	PIO_30	31				Switch3				
56	GBUF1	44								
57	GND									
58	PIO_31	32				Switch4				
59	PIO_32	33				Switch5				
60	PIO_35	34				Switch6				
61	GBUF0	43								
62	PIO_38	36				Switch7				
63	PIO_39	42				Switch8				
64	VCC									
65	GND									
66	D0	41						D0	D0	
67	D1	40						D1	D1	
68	PIO_52	37								
69	PIO_53	6								
70	PIO_54	7								
71	PIO_55	8								
72	GND									
73	PIO_60	9								
74	PIO_61	77								
75	D2	39						D2	D2	
76	D3	38						D3	D3	
77	CVCC									
78	CGND									
79	D4	35						D4	D4	
80	D5	81						D5	D5	
81	VCC									
82	GND									
83	D6	80						D6	D6	
84	D7	10						D7	D7	
85	PIO_62	70								
86	PIO_63	66								
87	PIO_64	55								
88	XDONE	47								
89	GND	52								
90	WE_	62						/WE	/WE	
91	SLAVE	48								
92	OE_	61						/OE	/OE	
93	CE_	65						/CE	/CE	
94	RST_		D0 (2)							
95	VSYS	49								
96	VCC	54								
97	GND									
98	A0	3						A0	A0	

# XSTE5 CSoC Board Manual

TE505		Pins	Parallel Port	VGA	PS/2	Switches	LEDs	Flash RAM	SRAM	Prog. Osc.
99	A1	4						A1	A1	
100	A2	5						A2	A2	
101	A3	78						A3	A3	
102	GND									
103	A4	79						A4	A4	
104	A5	82						A5	A5	
105	A6	83						A6	A6	
106	A7	84						A7	A7	
107	PIO_65		S4 (13)							
108	PIO_66		S5 (12)							
109	GND									
110	CVCC**									
111	CGND**									
112	A8	59						A8	A8	
113	A9	57						A9	A9	
114	A10	51						A10	A10	
115	A11	56						A11	A11	
116	VCC									
117	PIO_67		S6 (10)							
118	PIO_68		S3 (15)							
119	A12	50						A12	A12	
120	A13	58						A13	A13	
121	GND									
122	PIO_69		C1 (14)							
123	PIO_70		C0 (1)							
124	A14	60						A14	A14	
125	A15	28						A15	A15	
126	A16	16						A16	A16	
127	A17	53						A17		
128	VCC									

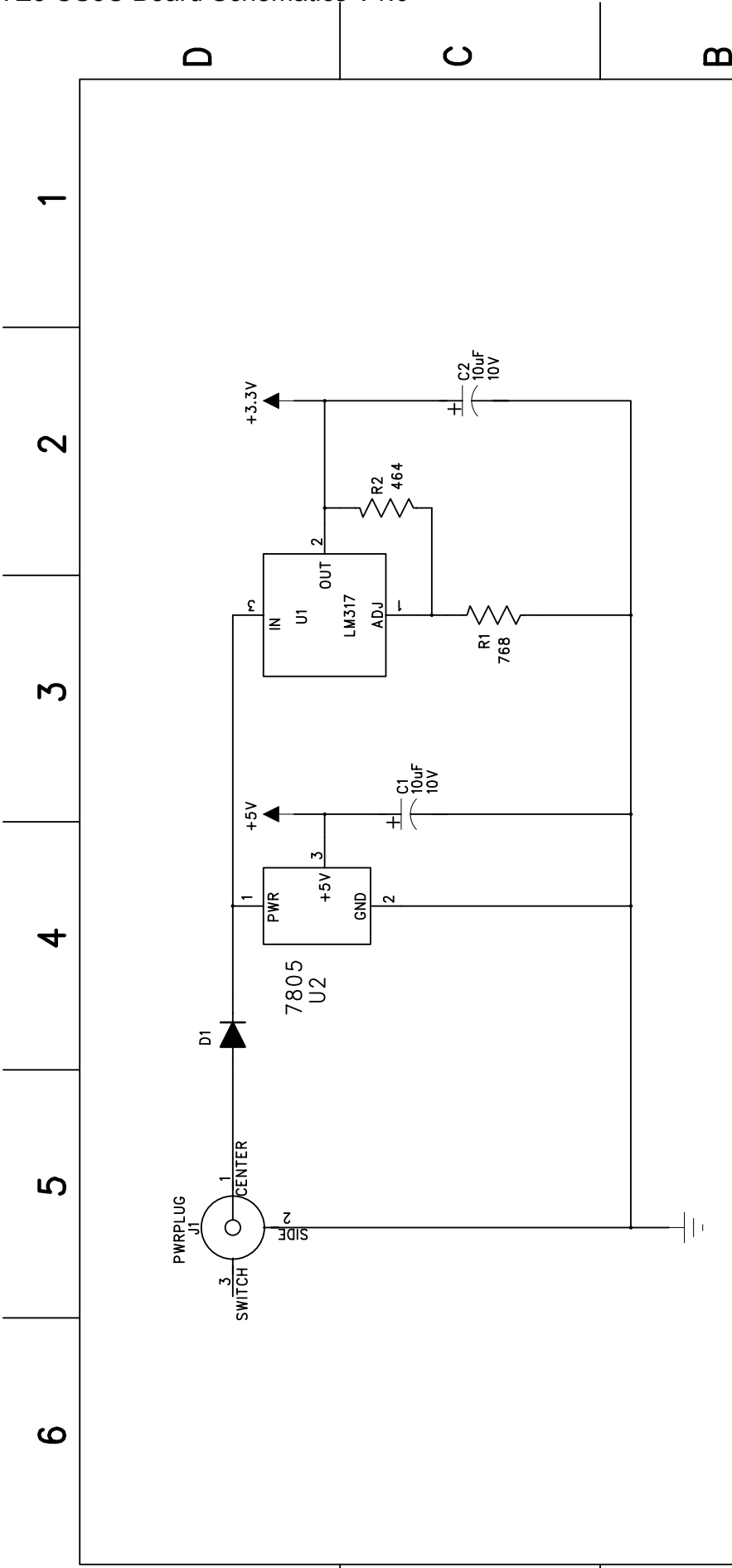

COMPANY: XESS Corp.		DRAWING NO:		REV: 1.0
TITLE: XSTE5 Board Power Conditioning		CODE:	SIZE:	
DRAWN:	DATED:	CHECKED:	DATED:	QUALITY CONTROL:
SCALE:			SHEET: 1 of 7	

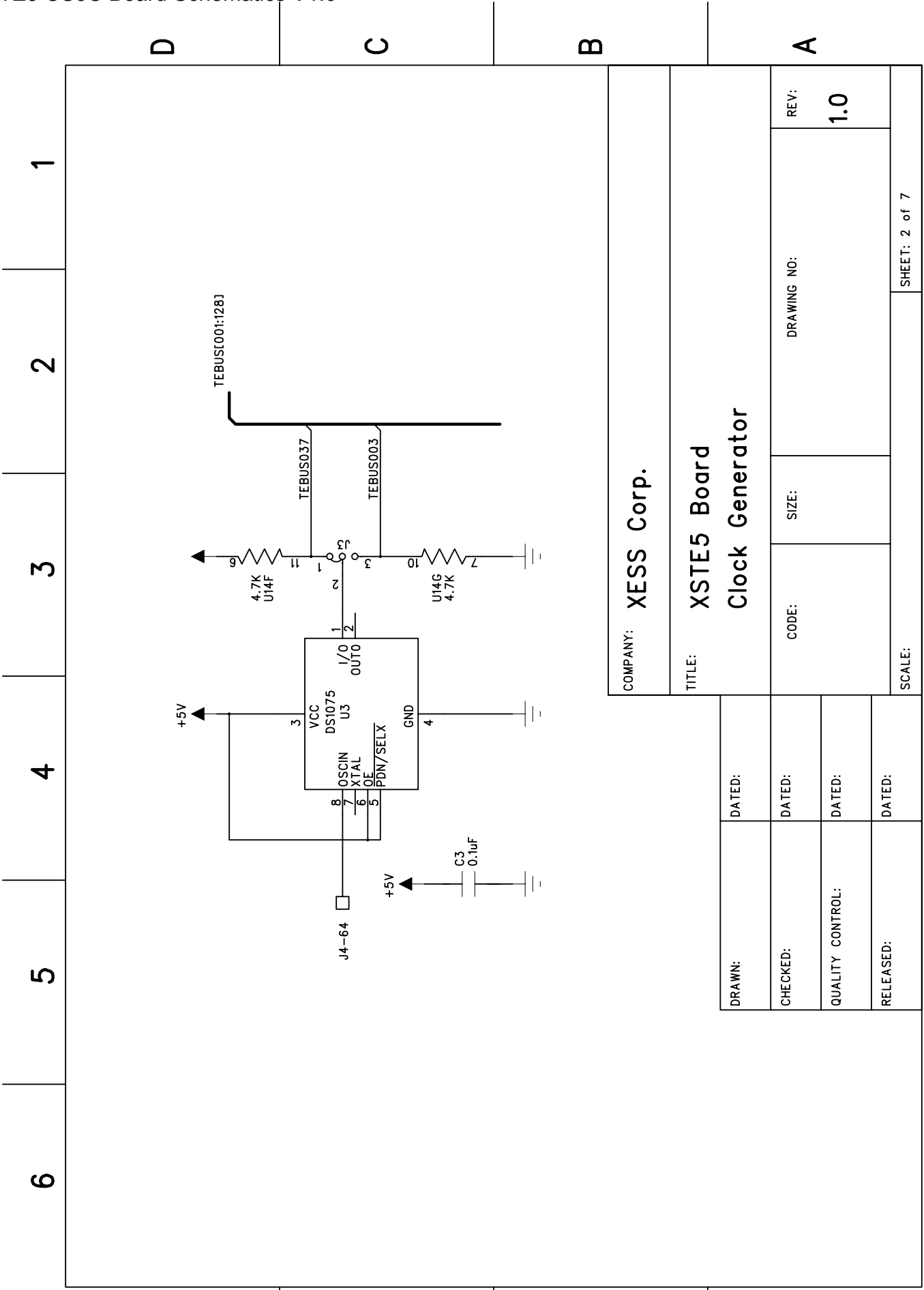

COMPANY: XESS Corp.		DRAWING NO:		REV: 1.0
TITLE: XSTE5 Board Clock Generator		CODE:	SIZE:	
DRAWN:	DATED:	CHECKED:	DATED:	QUALITY CONTROL:
SCALE:			SHEET: 2 of 7	

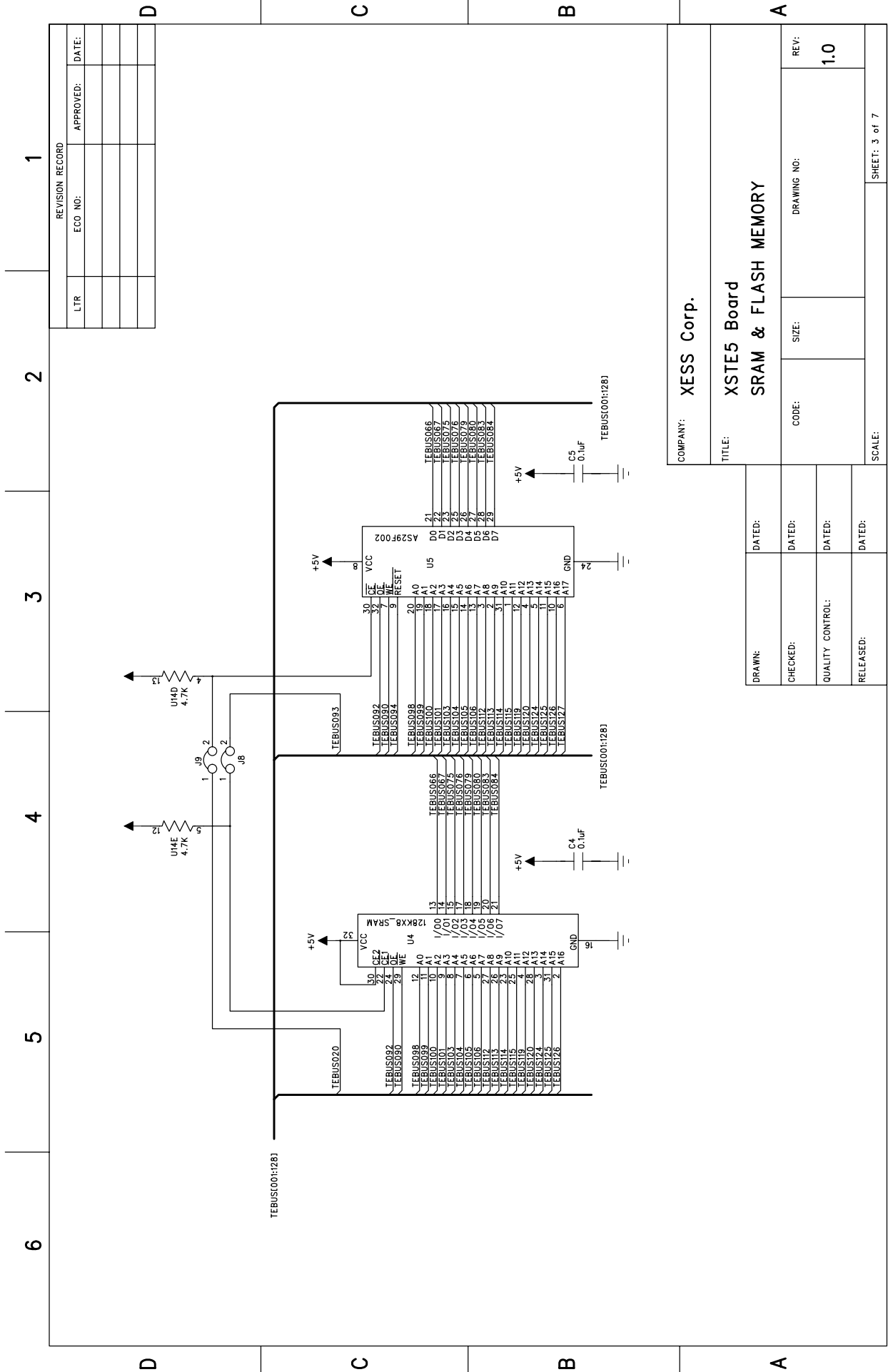

COMPANY: XESS Corp.			
TITLE: XSTE5 Board SRAM & FLASH MEMORY			
DRAWN:	DATED:	CODE:	SIZE:
CHECKED:	DATED:	DRAWING NO:	REV: 1.0
QUALITY CONTROL:	DATED:	SCALE:	SHEET: 3 of 7
RELEASED:	DATED:		

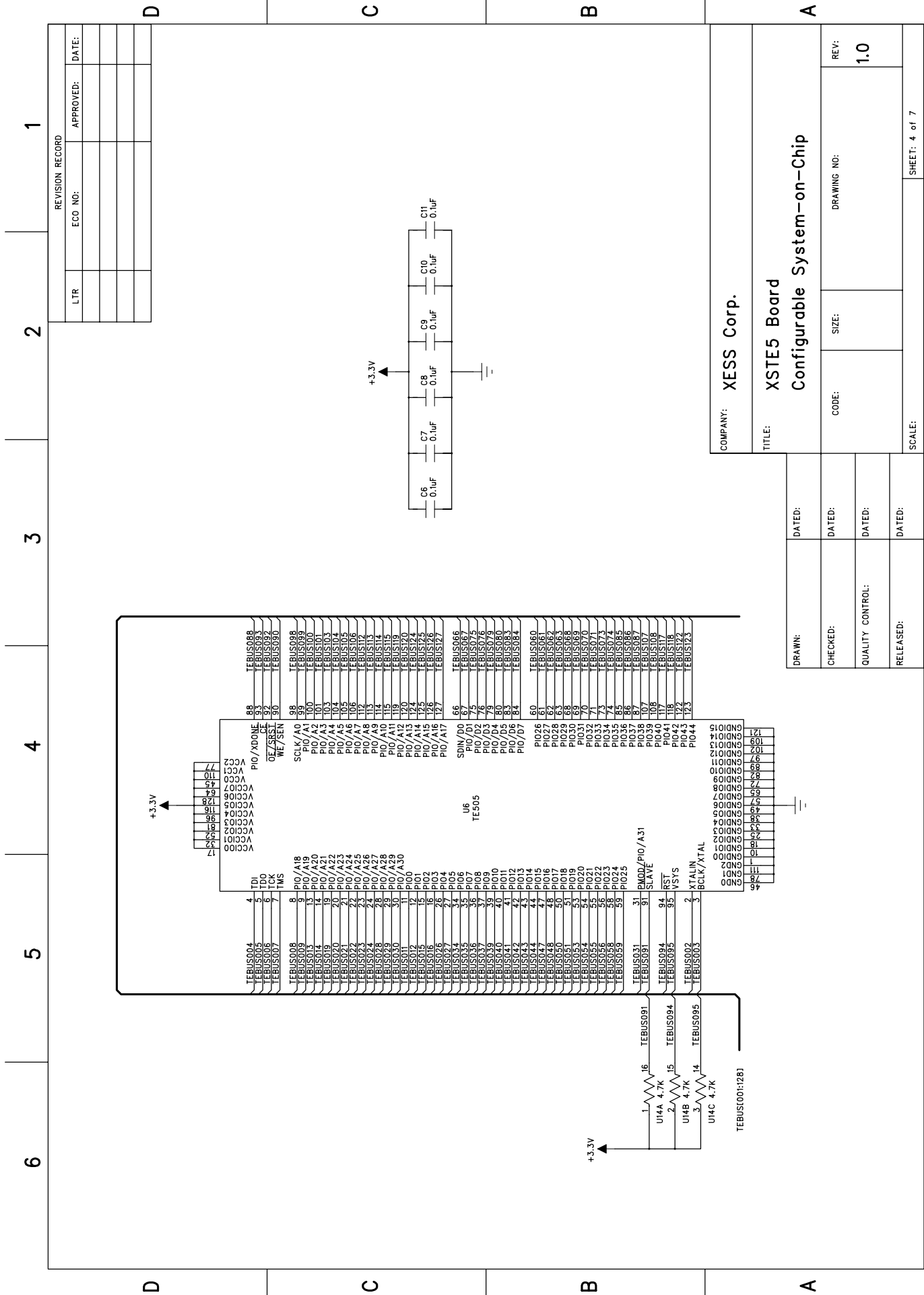

COMPANY: XESS Corp.	
TITLE: XSTE5 Board Configurable System-on-Chip	
DRAWN:	DATED:
CHECKED:	DATED:
QUALITY CONTROL:	DATED:
RELEASED:	DATED:
CODE:	SIZE:
DRAWING NO:	
REV: 1.0	
SCALE:	SHEET: 4 of 7

# XSTE5 CSoC Board Schematics V1.0

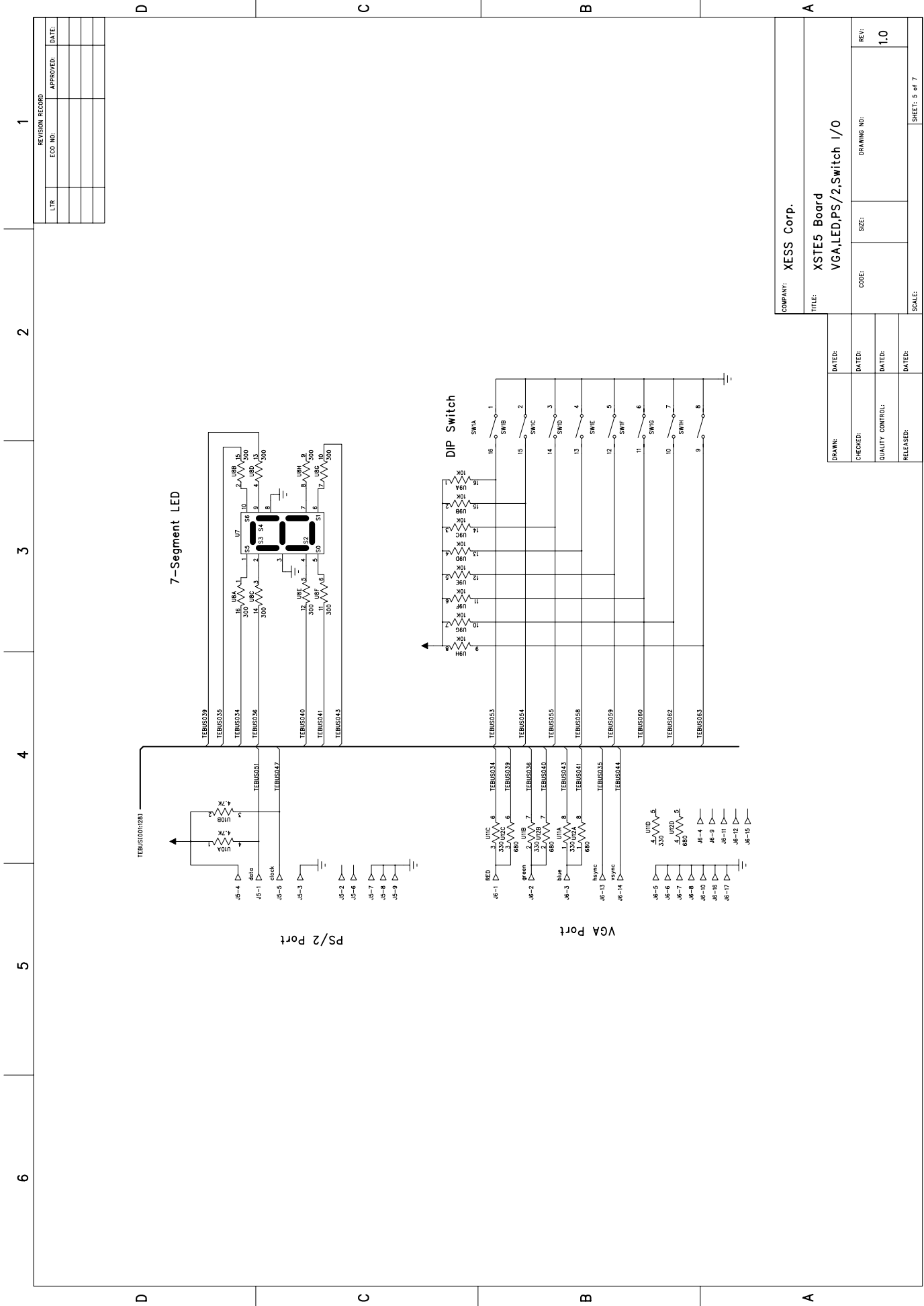

REVISION RECORD		
LT#	ECO NO.	DATE

COMPANY: XESS Corp.	
TITLE: XSTE5 Board VGA,LED,PS/2,Switch I/O	
DRAWN:	DATE:
CHECKED:	DATE:
QUALITY CONTROL:	DATE:
RELEASED:	DATE:
CODE:	SIZE:
DRAWING NO:	
REV: 1.0	
SCALE:	SHEET: 5 of 7



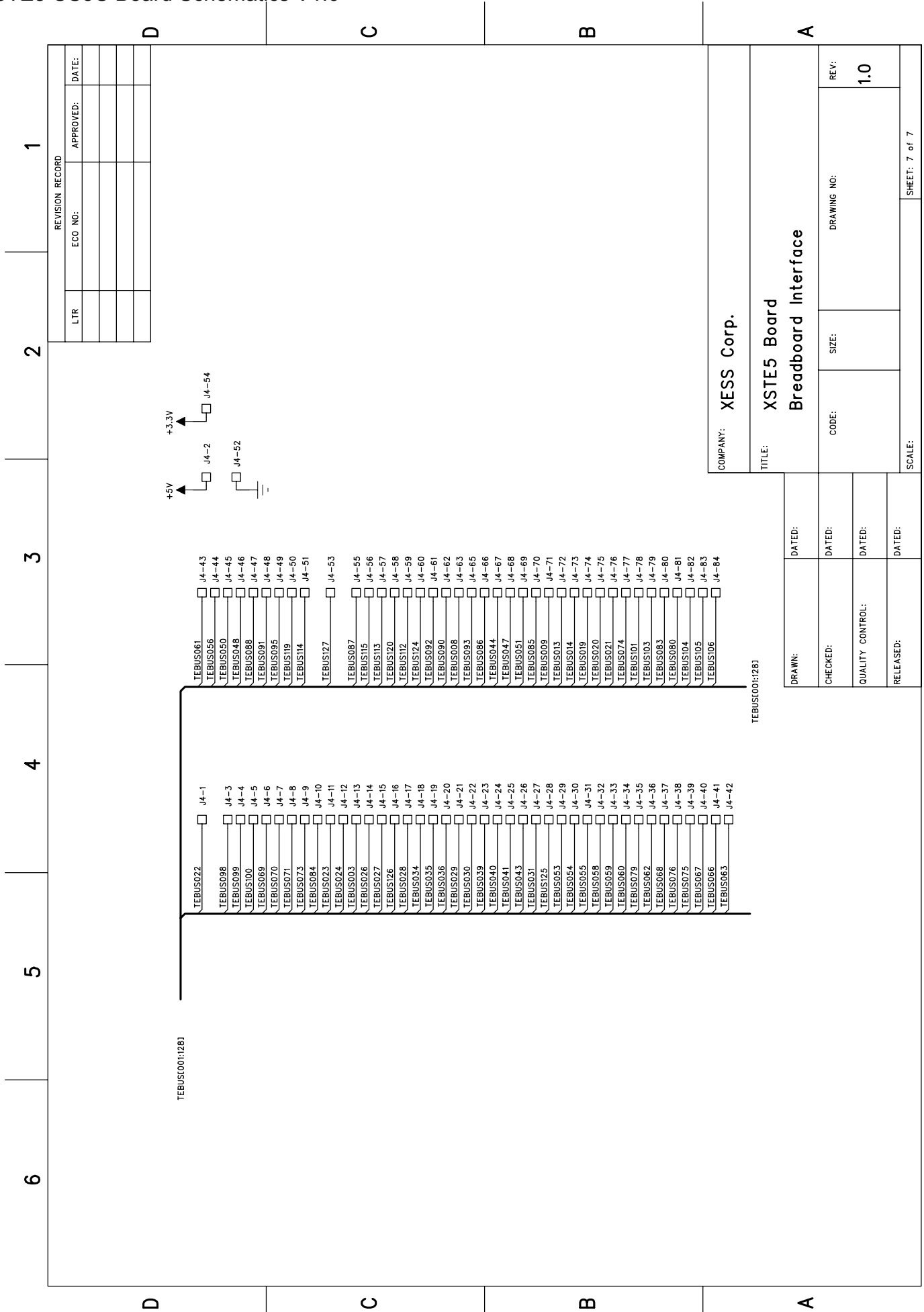

REVISION RECORD		
LTR	ECCO NO:	APPROVED:

COMPANY: XESS Corp.	
TITLE: XSTE5 Board Breadboard Interface	
CODE:	DRAWING NO:
SIZE:	REV: 1.0
SCALE:	SHEET: 7 of 7

DRAWN:	DATED:
CHECKED:	DATED:
QUALITY CONTROL:	DATED:
RELEASED:	DATED: