

StickIt! Buttons V1.0 User Manual

How to install and use your new StickIt! Buttons Module

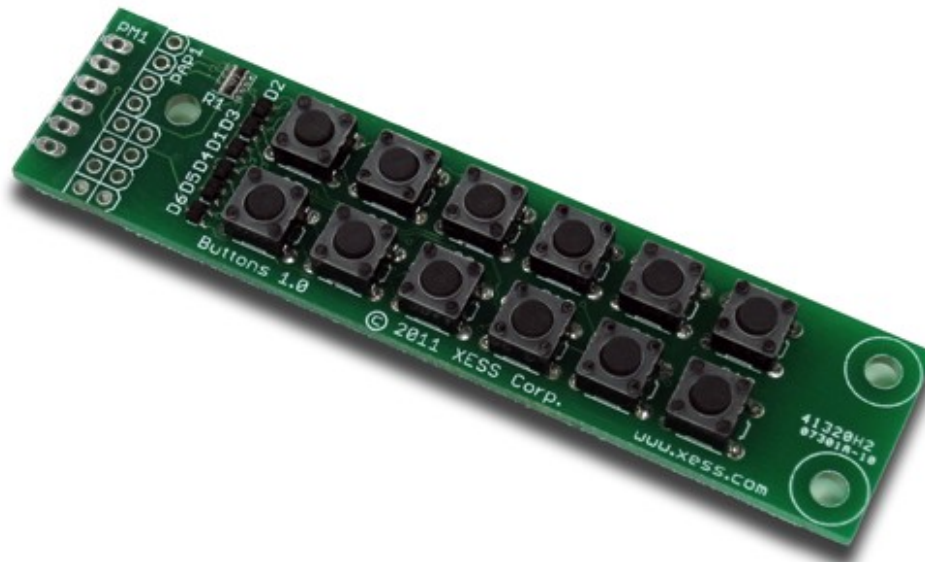

XESS is disclosing this Document and Intellectual Property (hereinafter “the Design”) to you for use in the development of designs to operate on, or interface with XESS hardware devices. XESS expressly disclaims any liability arising out of the application or use of the Design. XESS reserves the right to make changes, at any time, to the Design as deemed desirable in the sole discretion of XESS. XESS assumes no obligation to correct any errors contained herein or to advise you of any correction if such be made. XESS will not assume any liability for the accuracy or correctness of any engineering or technical support or assistance provided to you in connection with the Design.

THE DESIGN IS PROVIDED “AS IS” WITH ALL FAULTS, AND THE ENTIRE RISK AS TO ITS FUNCTION AND IMPLEMENTATION IS WITH YOU. YOU ACKNOWLEDGE AND AGREE THAT YOU HAVE NOT RELIED ON ANY ORAL OR WRITTEN INFORMATION OR ADVICE, WHETHER GIVEN BY XESS, OR ITS AGENTS OR EMPLOYEES. XESS MAKES NO OTHER WARRANTIES, WHETHER EXPRESS, IMPLIED, OR STATUTORY, REGARDING THE DESIGN, INCLUDING ANY WARRANTIES OF MERCHANTABILITY, FITNESS FOR A PARTICULAR PURPOSE, TITLE, AND NONINFRINGEMENT OF THIRD-PARTY RIGHTS.

IN NO EVENT WILL XESS BE LIABLE FOR ANY CONSEQUENTIAL, INDIRECT, EXEMPLARY, SPECIAL, OR INCIDENTAL DAMAGES, INCLUDING ANY LOST DATA AND LOST PROFITS, ARISING FROM OR RELATING TO YOUR USE OF THE DESIGN, EVEN IF YOU HAVE BEEN ADVISED OF THE POSSIBILITY OF SUCH DAMAGES. THE TOTAL CUMULATIVE LIABILITY OF XESS IN CONNECTION WITH YOUR USE OF THE DESIGN, WHETHER IN CONTRACT OR TORT OR OTHERWISE, WILL IN NO EVENT EXCEED THE AMOUNT OF FEES PAID BY YOU TO XESS HEREUNDER FOR USE OF THE DESIGN. YOU ACKNOWLEDGE THAT THE FEES, IF ANY, REFLECT THE ALLOCATION OF RISK SET FORTH IN THIS AGREEMENT AND THAT XESS WOULD NOT MAKE AVAILABLE THE DESIGN TO YOU WITHOUT THESE LIMITATIONS OF LIABILITY.

The Design is not designed or intended for use in the development of on-line control equipment in hazardous environments requiring fail-safe controls, such as in the operation of nuclear facilities, aircraft navigation or communications systems, air traffic control, life support, or weapons systems (“High-Risk Applications”). XESS specifically disclaims any express or implied warranties of fitness for such High-Risk Applications. You represent that use of the Design in such High-Risk Applications is fully at your risk.

© 2012 XESS, Inc. XESS, the XESS logo, and other designated brands included herein are trademarks of XESS Corporation. PMOD is a trademark of Digilent Inc. All other trademarks are the property of their respective owners.



This document is licensed under the Attribution-ShareAlike 3.0 Unported license, available at <http://creativecommons.org/licenses/by-sa/3.0/>.

StickIt! Buttons V1.0 User Manual
MAN004 (V1.0) February 4, 2012

The following table shows the revision history for this document.

Date	Version	Revision
01/18/12	1.0	Initial release for StickIt! Buttons module V1.0.

Table of Contents

- C.1 Preliminaries..... 1**
 - Getting Help!..... 1
 - Take Notice!..... 1
 - Packing List..... 1
- C.2 Setup..... 2**
 - Inserting Your StickIt! Buttons Module Into Your StickIt! Board..... 2
 - Inserting Into a PMOD Socket..... 2
 - Inserting Into a Wing Socket..... 3
- C.3 Operation..... 5**
- C.4 Using the Module..... 7**
- A.1 I/O Locations..... 8**
- A.2 Schematic..... 9**

C.1 Preliminaries

Here's some helpful information before getting started.

Getting Help!

Here are some places to get help if you encounter problems:

- If you can't get the StickIt! Buttons module to work, send an e-mail message describing your problem to help@xess.com or submit a problem report at <http://www.xess.com/help.php>. Our web site also has
 - answers to frequently-asked-questions,
 - example designs, application notes and tutorials,
 - a forum where you can post questions.

Take Notice!

It's pretty hard to get in trouble with this module.

Packing List

Here is what you should have received in your package:

- a StickIt! Buttons module.
- PMOD™ male header.
- Wing male headers (8-pin & 4-pin).

C.2 Setup

The StickIt! Buttons module provides an array of twelve pushbuttons that you can insert into a four-bit or eight-bit PMOD or a Wing socket on your StickIt! board.

Inserting Your StickIt! Buttons Module Into Your StickIt! Board

Inserting Into a PMOD Socket

To use the StickIt! Buttons module with a PMOD socket, first solder the included male PMOD header to the module as shown. (**To insure a stable connection, only use a header with 0.25" square pins.**)

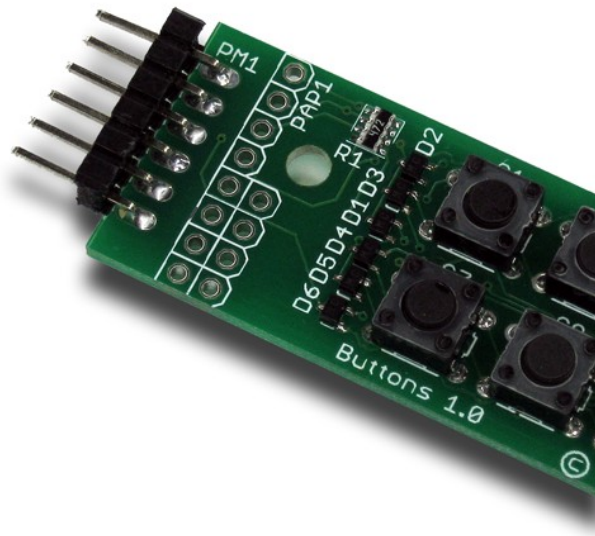

Then insert the module into one of the PMOD sockets on the StickIt! Board. (This module does not directly connect to any power supply so there is no need to change the setting of the voltage selection jumper of the PMOD socket.)

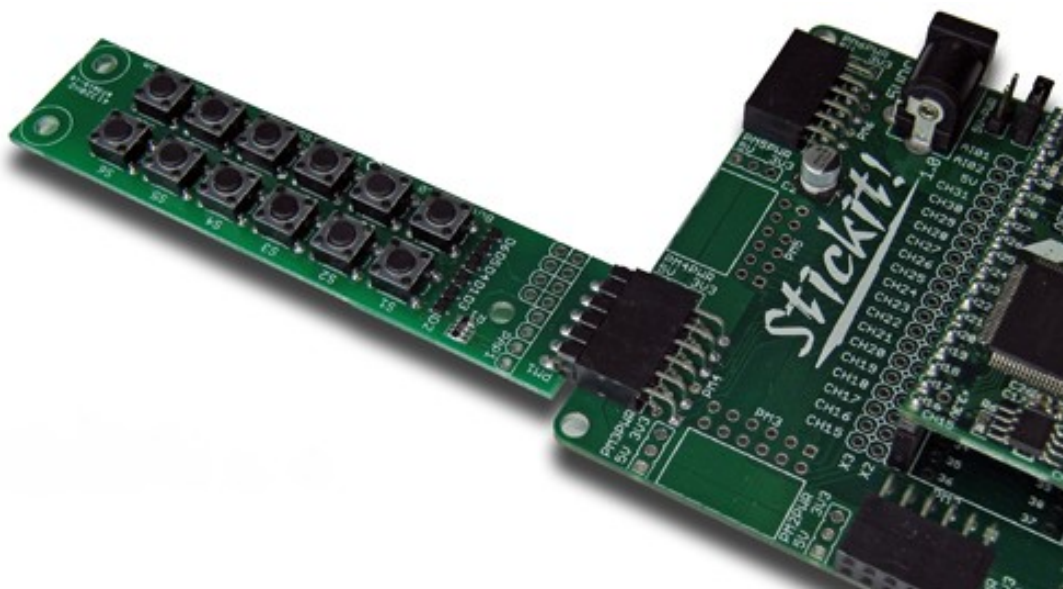

Inserting Into a Wing Socket

To use the StickIt! Buttons module with a Wing socket, first solder the included male Wing headers to the module as shown. (**To insure a stable connection, only use a header with 0.25" square pins.**)

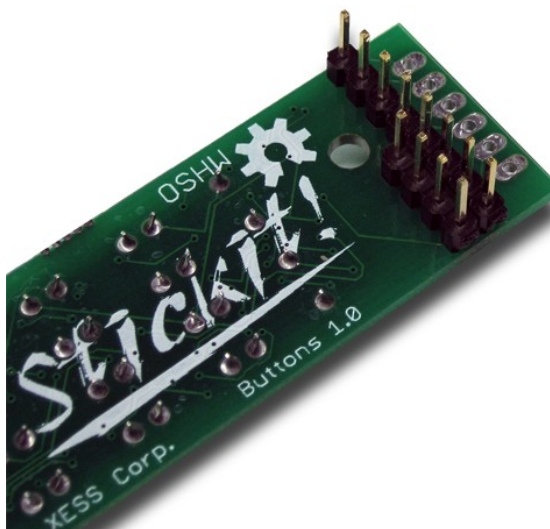

C.3 Operation

This chapter describes the operation of the StickIt! Buttons module using a simplified schematic. You can find a complete [schematic](#) at the end of this manual.

By adding a few diodes, twelve normally-open buttons can be scanned using only four I/O signals. You can see how this works by examining a simpler case of scanning six buttons using three I/Os.

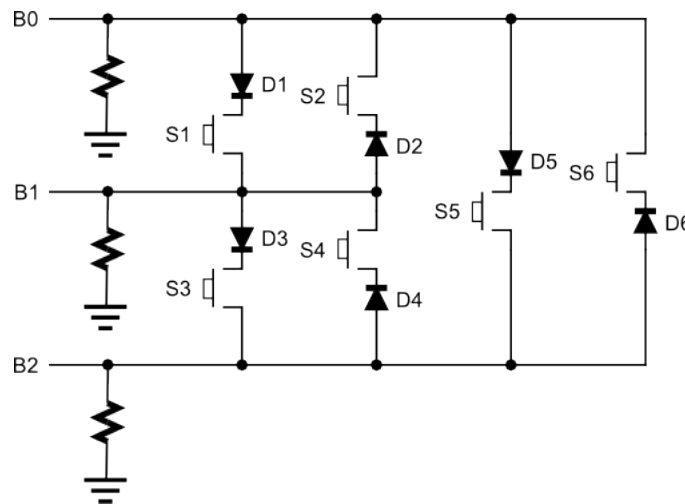

Driving signal B0 and sensing the level on B1 will detect whether button S1 is open or closed. If closed, then B1 is driven high by B0; if open, then B1 is pulled low by the attached pull-down resistor. In either case, the state of button S2 will not have any effect because diode D2 blocks B0 from driving B1.

Next, by reversing their roles and driving B1 while sensing B0, the state of S2 is determined. Now diode D2 conducts while D1 prevents button S1 from interfering with the scan.

Using this technique, all six buttons can be scanned by sequentially driving each of the signals while sensing the other two.

Note that this fails if two or more buttons are pressed at the same time. For example, if B0 is driven and S1 and S3 are both pressed, then a high level is sensed on B1 and it continues from there through D3 and S3 to also be sensed on B2. But this is indistinguishable from the case when S1 and S5 are both pressed, because B1 and B2 would both be high then as well. Multiple button presses are detected by looking for scans where more than one sense line is driven high and ignoring the results of the entire scan.

The table below shows which button on the StickIt! Buttons module is scanned when a particular signal is driven and another is sensed.

		Drive			
		B0	B1	B2	B3
Sense	B0	N/A	S4	S5	S6
	B1	S1	N/A	S9	S10
	B2	S2	S7	N/A	S12
	B3	S3	S8	S11	N/A

C.4 *Using the Module*

To use the StickIt! Buttons module, you will need to do the following:

- Create a Xilinx ISE FPGA project and write some HDL code for scanning the buttons.
- Attach the module to either a PMOD or Wing socket on the StickIt! board.
- Determine the channel signals on the PMOD or Wing socket that connect to each I/O pin of the module.
- Find which FPGA pin of the XuLA board connects to each channel signal.
- Make a UCF file associating each FPGA pin with an I/O pin of the module.
- Include the UCF file in your ISE project.

That's a lot of work just to scan some buttons, so we've done most of it for you. Just go to <http://github.com/xesscorp/StickIt>. There, you will find a subdirectory with a Xilinx ISE project that includes:

- a button-scanning HDL module,
- an example that uses the button-scanning module and an LED Charlieplexing module to detect and display the pressed button,
- and a UCF file containing the FPGA pin assignments to use when installing the StickIt! Buttons module into any of the PMOD or Wing sockets.

A.1 I/O Locations

The connections of the I/O signals to the PMOD and Wing headers of the StickIt! Buttons module are shown below.

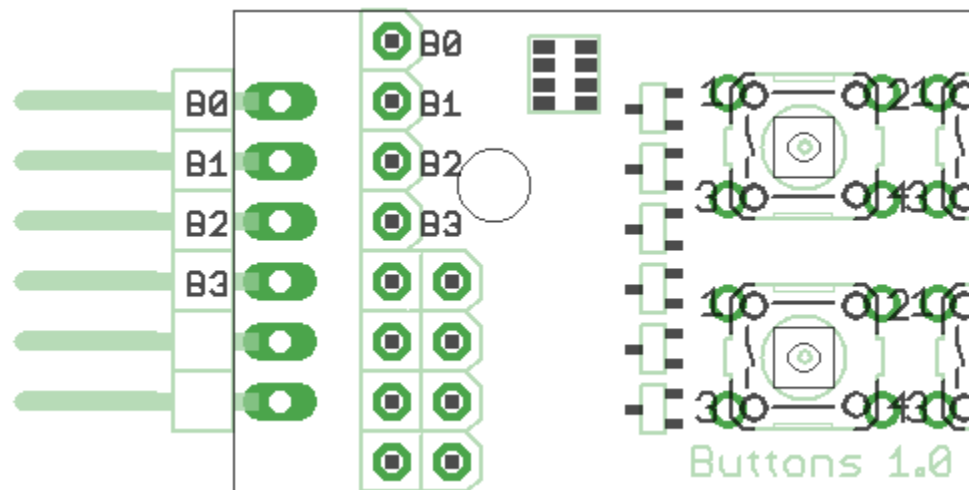

A.2 Schematic

